

iAeris

iAeris7 Indoor Air Quality Detector



* Please read this manual carefully before using this product

USER MANUAL

www.sysinnotec.com

Rev. 1.3 Oct. 2025

SYSINNO

IAERIS7 USER MANUAL



Contents

- [PACKAGE CONTENTS](#)
- [PRODUCT DESIGN/FEATURES](#)
 - [Front/Right side/Embedded Installation](#)
 - [Back site](#)
- [PRODUCT DIMENSIONS](#)
- [WALL MOUNT INSTALLATION](#)
- [STAND MOUNT INSTALLATION \(OPTIONAL\)](#)
- [USER INTERFACE](#)
 - [Home Screen](#)
 - [Information Screen](#)
- [DEVICE STATUS SCREEN](#)
- [ADVANCED SETTINGS:](#)
 - [Advanced Settings - Main Screen](#)
 - [Advanced Settings - Reset wi-fi settings](#)
 - [Advanced Settings - Configure Wi-Fi Hotspot](#)
 - [Advanced Settings - Change RS485 Baud Rate](#)
 - [Advanced settings - MODBUS Device Address](#)
 - [Advanced settings - Change main display mode](#)
 - [Advanced settings - Change Display Unit](#)
 - [Advanced settings - device restart](#)
- [CONNECT TO WI-FI HOTSPOT](#)
- [LOG IN TO THE CONFIGURATION WEBPAGE](#)
 - [Wireless \(Wi-Fi\) Setup Procedure](#)
- [CLOUD PLATFORM INTERFACE \(Optional\)](#)
 - [Register Account](#)
 - [Cloud Platform Login Homepage](#)
 - [Historical Data Trend Curve](#)
 - [Customer Area Functionality](#)
- [INSTALLATION POSITION RECOMMENDATIONS](#)
- [PRECAUTIONS](#)
- [ATTACHMENT: IAERIS7 WEB SETTINGS GUIDE](#)

PACKAGE CONTENTS

- iAeris main unit
- Adapter [1]
- Product warranty card
- Screw package

PRODUCT DESIGN / FEATURES

Front

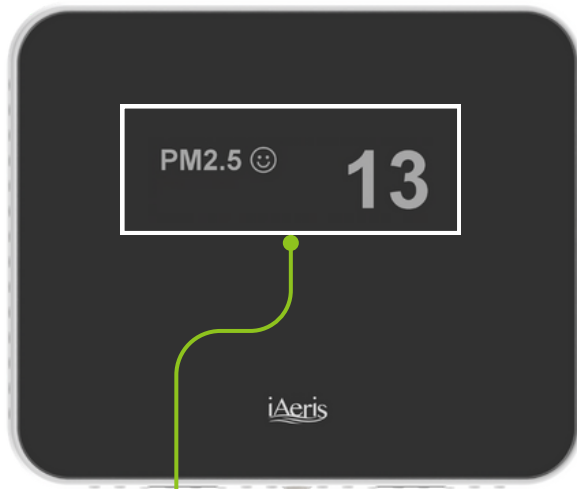

Display Screen

Right Side

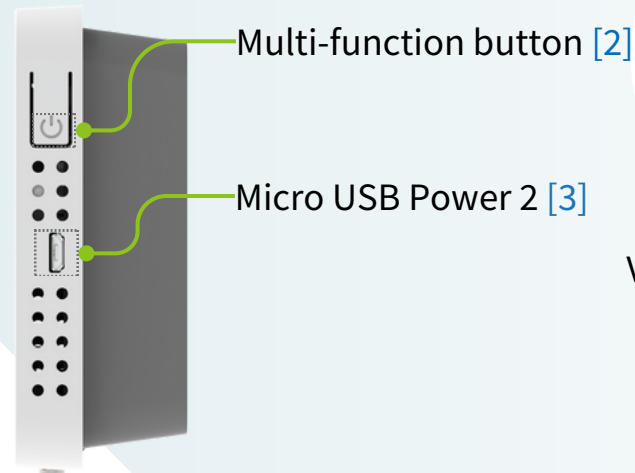

Embedded Installation

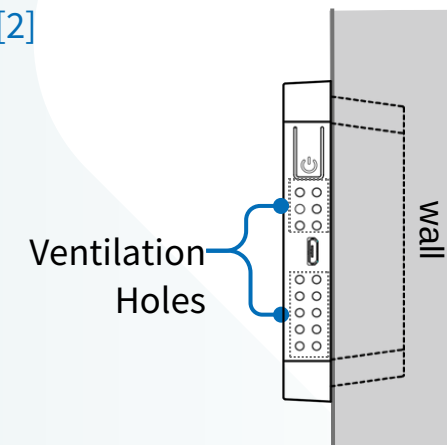

NOTES:

- [1] Transformer power cord length is 1.5m
- [2] Hold the multifunction button for 10sec. to reset Wi-Fi
- [3] There are 2 Micro USB Powers on right and back sites. Avoid using both Micro USB power1 & 2 ports simultaneously.

This product can be embedded into the wall, but do not block the vents.

[See \[Product Dimensions\] page for details](#)

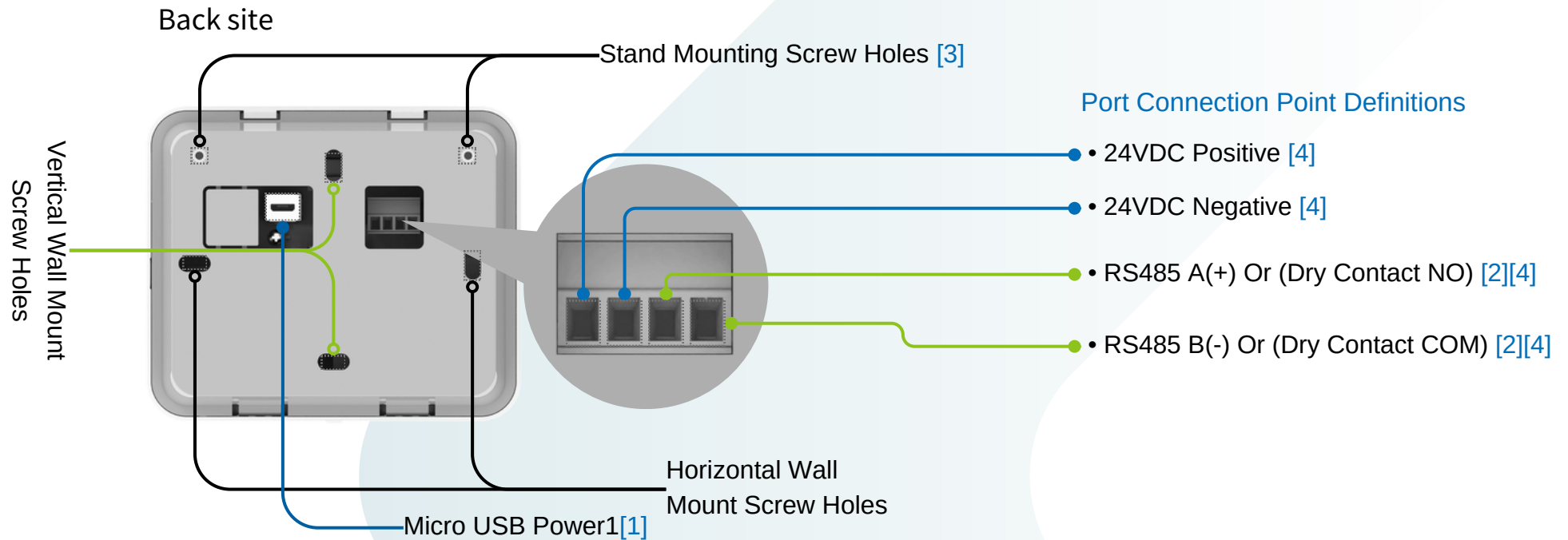

NOTES:

[1] There are 2 Micro USB Powers on right and back sites. Avoid using both Micro USB power1 & 2 ports simultaneously.

[2] Default is RS485 connection, optional dry contact function (if dry contact is selected, RS485 communication cannot be used simultaneously).

[3] Stand mount is an optional accessory

[4] Communication cable recommendations:

RS485: AWG22 dual isolated control cable

24VDC: AWG24AWG19 multi-core power cable

Dry contact: AWG24AWG19 multi-core power cable

COMMUNICATION INTERFACE:

RS485 Communication Function

- RS-485 is directional, please pay attention to the A(+) and B(-) positions when wiring.
- Communication format adopts Modbus RTU format, please use devices and equipment with Modbus RTU Master function.

Wireless Network Function

- please refer to the [WiFi setup process](#) instructions.
- Supports HTTP, MQTT, and Modbus TCP formats.

Dry Contact Function (optional)

- This product can be set with one dry contact, serving as a signal source to activate external devices. Use proper wiring for connection [4].

PRODUCT DIMENSIONS

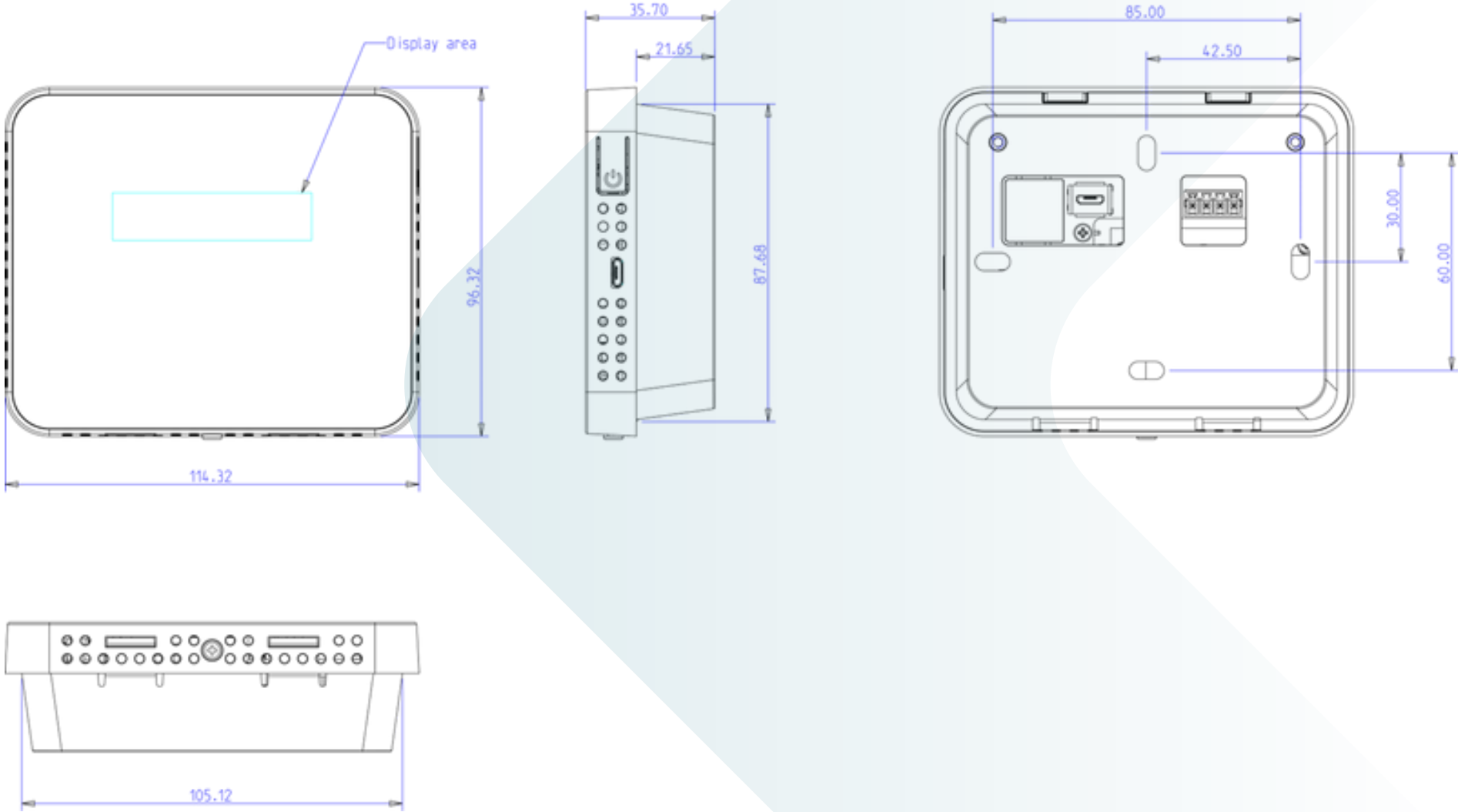

Unit: mm

WALL MOUNT INSTALLATION



1
Loosen the bottom screws.

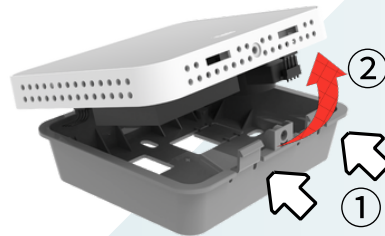

2
① Press the bottom latch.
② Lift the machine body to detach it from the back cover.

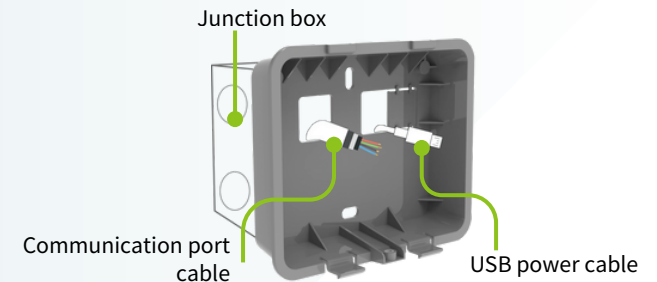

3
Position the back cover on the wall [1] or wiring box and route the Micro USB Power cord as needed.

[1] See [\[Installation Position Recommendations\]](#) page

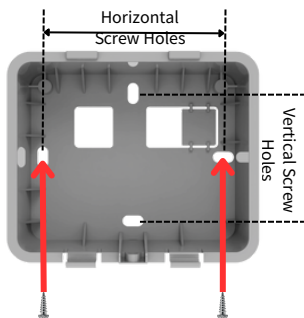

4
Secure the back cover to the wall using the provided screws [2].

[2] Choose screw holes based on wiring box specifications: horizontal or vertical.

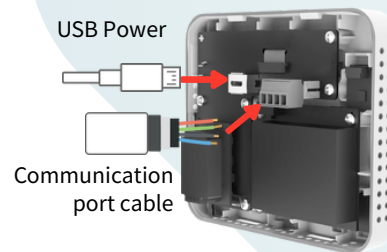

5
Install the power cord [3] and communication port cable as needed.

[3] This product offers two power supply options. See page 17 for details under "Power Supply Specifications."



6
① Reattach the machine body and secure the bottom latch of the back cover.
② Lock the fixing screws.

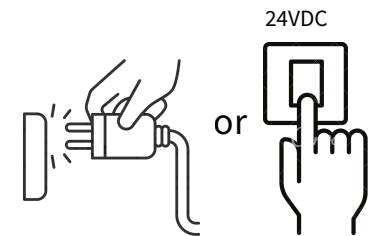

7
Plug in the adapter or power the device with 24VDC.

STAND MOUNT INSTALLATION (OPTIONAL)



1 Attach the stand to the detector back cover with the included screws.



2 Set the detector with stand on a flat surface.

- Ensure the detector is placed level.
- Place it away from the body and heat sources for accuracy.
- Ensure the vents are unobstructed for proper airflow.
- Refer to page 16 for installation position recommendations.



Micro USB Power 1

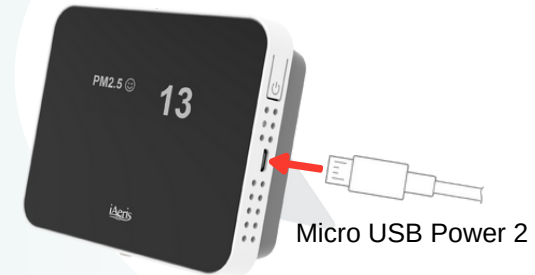

Micro USB Power 2

3 Plug in the transformer to power on the device.

- This product has one Micro USB power port on the back and one on the side. You can choose to use either as needed.
- Do not use Micro USB power 1 and 2 simultaneously.

USER INTERFACE

Users can check indoor air quality and iAeris7 information on the front display. After powering on, a welcome screen appears before entering the main interface. The main interface offers three display modes (Sleep, Standby, IAQ), selectable in advanced settings. Users can switch between the main interface and information screens by pressing the multifunction button.

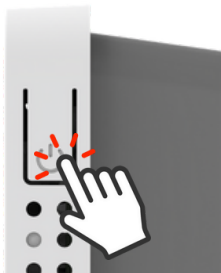
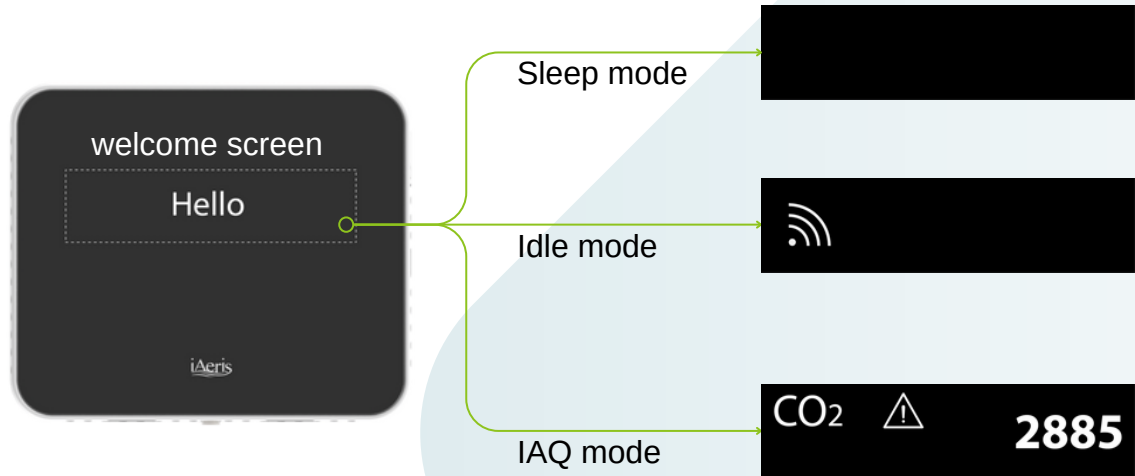

Single-tap :
Switch between different
device information screens

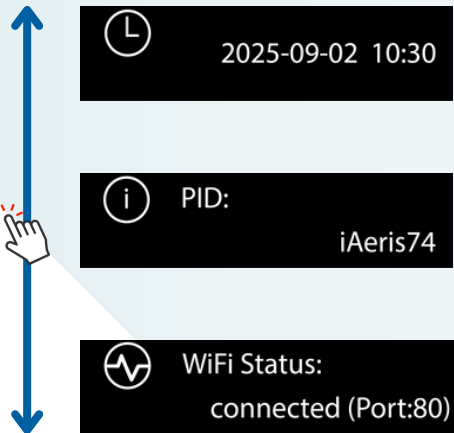

- Tap the multifunction button to view different information.
- Double-tap the multifunction button to lock the screen.

Gestures:



Tap: Single press the multifunction button

Sleep Screen

- The screen is turned off and shows no information.
- Stays off normally to save power, suitable for light-sensitive environments.

Standby Screen

- iAeris7 shows the device status and air quality using icons while in standby.
- Normally, the screen only displays Wi-Fi status, alert icons, and RS-485 communication status (factory default).

IAQ Screen

- Rotates through current air factor levels; shows alert icons if limits are exceeded.
- Continuously displays air quality information.

Time Screen

- Displaying Device Date and Time.

Product Info Screen

- Displays product-related information.
- Includes device serial number, software version, and similar details.

Device Status Screen

- Displays the device status. such as Wi-Fi connection status, etc.

HOME SCREEN

1 Standby Screen



Wi-Fi Status Alert Icon RS-485 Icon

Wi-Fi Status Description:

| Mode | Status Description | Icon |
|---------|--|------|
| AP | Wi-Fi Hotspot On This icon shows the iAeris7 Wi-Fi hotspot is active, allowing device setup via phone or computer. | |
| AP | Wi-Fi Hotspot Off To reactivate, go to the settings menu. | |
| Station | Wi-Fi Connected | |
| Station | Wi-Fi Connection Error Check the router or press and hold to reset. | |
| NO WiFi | Wi-Fi Module Not Installed / Wi-Fi Disabled | N/A |

Alert Icon : This icon indicates poor air quality.

RS485 Icon: This icon appears when the device is communicating via RS-485.

2 IAQ Screen

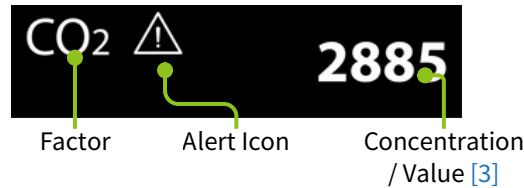

Factor Alert Icon Concentration / Value [3]

Displays detailed air quality (IAQ) in a rotating cycle.[1]

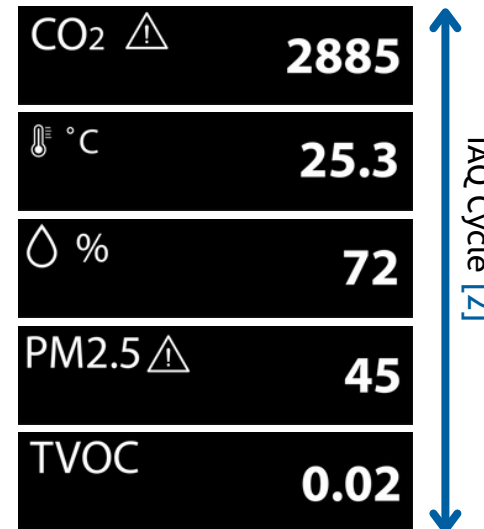

IAQ Cycle [2]

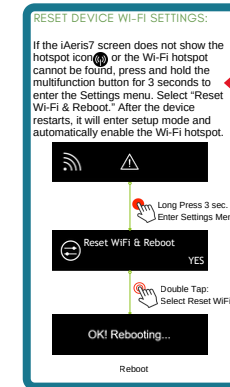

3 Double-tap: Lock the current screen



Double-tap the multifunction button the main screen to lock the current screen and display the lock icon .

4 Press and hold to reset the device

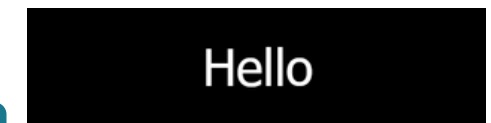

- Press and hold for 3 seconds → the screen on the left appears (do not release). Keep holding until 10 seconds → enters 'WiFi Reset Settings' to reset WiFi and account password.
- Holding the multifunction button for 10 seconds will reset WiFi settings and restore the iAeris web login account and password to default [4].
- After restart, the WiFi hotspot will turn on automatically.

NOTES:

- [1] The above icons display: CO₂, Temperature (°C), Humidity (%), PM2.5, and TVOC
- [2] Each factor is displayed for 5 seconds.
- [3] Concentration/value is shown in the set units. See [Advanced Settings – Change Display Units](#) for details.
- [4] Default username: [admin], password: [admin]

INFORMATION SCREEN

1. Time Screen

This screen displays the current date and time of the device [1]

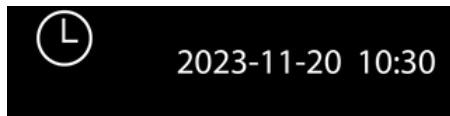

- Format: [YYYY-MM-DD HH:MM]

2. Product Info Screen

This screen displays the device model (PID), serial number, and firmware version [2]

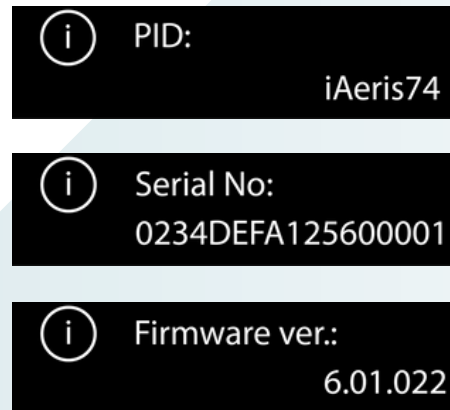

- PID: Product Model
- Serial NO: Device Serial Number
- Firmware ver.: Device Firmware Version

Play once from top to bottom

3. Device Status Screen

This screen displays connection and communication parameters [2][3]



Play once from top to bottom

NOTES:

[1] Returns to the main screen after approximately 10 seconds.

[2] Each screen shows for 5 seconds. After cycling through all screens, it returns to the main screen

[3] Please see [\[Device Status Screen\]](#) page

DEVICE STATUS SCREEN



1. WiFi Status Description:

| Mode | Status | Display Content / Example |
|--------------|---|----------------------------|
| AP-Mode | Device in AP Mode | AP-Mode (Port:80/502) |
| Station-Mode | WiFi Connected | connected (Port:80/502) |
| Station-Mode | Wi-Fi Connection Error Check the router or press and hold to reset [1] | disconnected (Port:80/502) |
| No WiFi | Wi-Fi Module Not Installed / Wi-Fi Disabled | No WiFi |

2. WiFi SSID (Network Name) Description:

| Mode | Status | Display Content / Example |
|--------------|---|---------------------------|
| AP-Mode | Wi-Fi Hotspot On | iAeris_XXXX[2] |
| AP-Mode | Wi-Fi Hotspot Hidden | iAeris_XXXX(Hidden)[2] |
| AP-Mode | Wi-Fi Hotspot Off | iAeris_XXXX(Auto-off)[2] |
| Station-Mode | WiFi Connected | Sysinno-AP[3] |
| Station-Mode | Wi-Fi Connection Error Check the router or press and hold to reset [1] | Sysinno-AP[3] |
| No WiFi | Wi-Fi Module Not Installed / Wi-Fi Disabled | --- |

3. Wi-Fi IP (Address) Description:

| Mode | Status | Display Content / Example |
|--------------|---|---------------------------|
| AP-Mode | Static IP | 192.168.4.1 (Static)[4] |
| Station-Mode | DHCP / Automatic IP | 192.168.1.10 (DHCP)[3] |
| Station-Mode | Set Static IP | 192.168.1.20 (Static)[3] |
| Station-Mode | Wi-Fi Connection Error Check the router or press and hold to reset [1] | Sysinno-AP[3] |
| No WiFi | Wi-Fi Module Not Installed / Wi-Fi Disabled | --- |

4. Baud rate Description:

| Status | Display Content / Example |
|--------------------------------|---------------------------|
| RS-485 Communication Baud Rate | 19200[3][4] |

5. Modbus ID (Station Number) Description:

| Status | Display Content / Example |
|---|---------------------------|
| Device station number in Modbus RTU communication | 1[3][4] |

NOTES:

- [1] See [\[Press and Hold to Reset Device\]](#)
- [2] XXXX is last 4 digits of Wi-Fi MAC
- [3] This table is for reference only. Displayed information may vary depending on the user's environment.
- [4] This is the device default value.

ADVANCED SETTINGS - MAIN SCREEN

From the main screen (Standby or IAQ), press and hold the multifunction button [3] for 3 seconds to enter the Settings menu.
Within the Settings menu, single-tap [1] or double-tap [2] the multifunction button to navigate and apply settings.

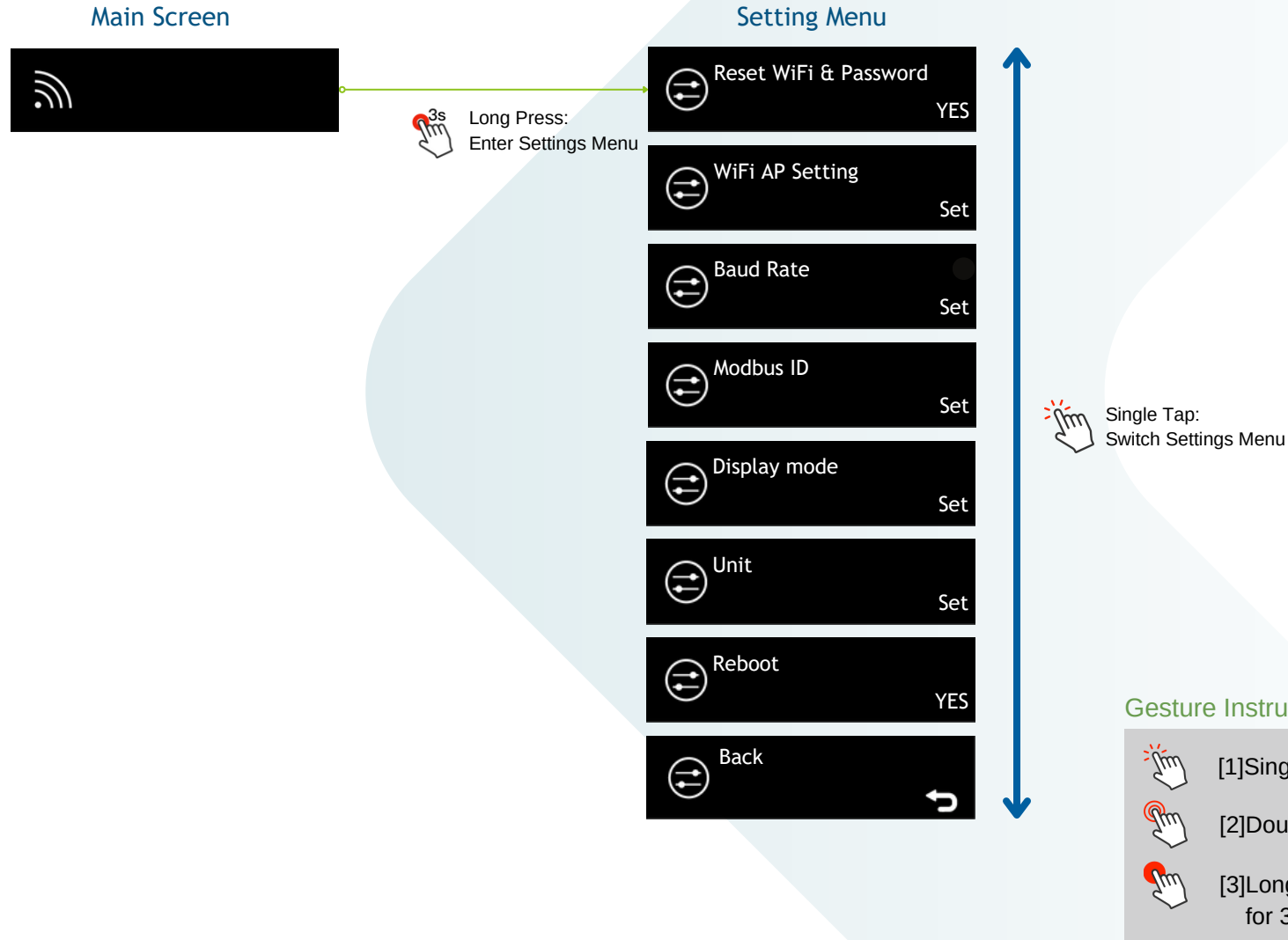

ADVANCED SETTINGS - RESET WI-FI SETTINGS

- **[Reset WiFi & Password]** : Resets Wi-Fi settings and restores the web interface username and password to default [1]

See [\[Advanced Settings\]](#) for details, After entering the Advanced Settings menu, select the [Reset WiFi & Password] page. This function allows users to restore the device Wi-Fi to factory settings. Double-tap the multifunction button to confirm. The screen will display **OK! Rebooting...** and the device will restart. After restarting, the Wi-Fi hotspot will automatically enable, allowing users to set up the Wi-Fi connection again [2]





NOTES:

[1] Default username: [admin], password: [admin]

[2] This page functions the same as [\[Press and Hold to Reset\]](#)

Gesture Instructions

-  [1]Single Tap: Press the button once
-  [2]Double Tap: Press the button twice

ADVANCED SETTINGS - CONFIGURE WI-FI HOTSPOT

- **[WiFi AP Setting]** : Configure the Wi-Fi hotspot function.

see [\[Advanced Settings - Main Screen\]](#) for details. After entering the Advanced Settings menu, select the [Wi-Fi AP Setting] page. The Wi-Fi hotspot has three modes. Double-tap the multifunction button to enter the submenu.: [1]

- **[Broadcast SSID (Visible)]** :
 - Broadcasts the Wi-Fi hotspot signal publicly, allowing all devices to find and connect.
- **[Hide SSID (Hidden)]** :
 - Hides the Wi-Fi hotspot; users must manually enter SSID and password to connect.
- **[Auto turn off when idle (30mins)]** :
 - Temporarily broadcasts the Wi-Fi hotspot and turns it off after **30 minutes** of inactivity.[2]

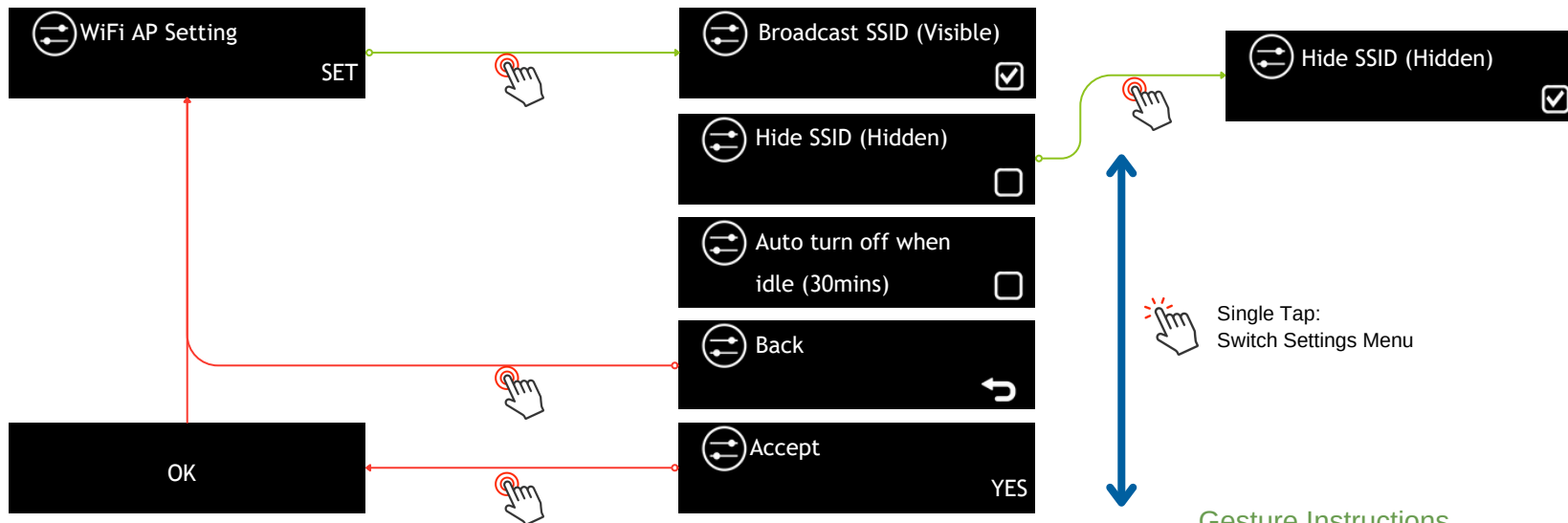

NOTES:

- [1] If there is no operation within 10 seconds:
- Changed settings will be applied automatically.
 - If no changes are made, the menu returns to the previous level.
- [2] To reactivate the Wi-Fi hotspot, restart the device or select another mode.

Gesture Instructions

- [1]Single Tap: Press the button once
- [2]Double Tap: Press the button twice

ADVANCED SETTINGS - CHANGE RS485 BAUD RATE

- **[Baud Rate]** : Change RS485 Baud Rate

See [\[Advance Settings - Main Screen\]](#) for details. After entering the Advanced Settings menu, select the [Baud Rate] page. Double-tap the multifunction button to confirm and enter the submenu: [1]

The iAeris7 default is 19200 bps. Supported baud rates are:

600 bps, 1200 bps, 2400 bps, 4800 bps, 9600 bps, 19200 bps, 115200 bps, 230400 bps.

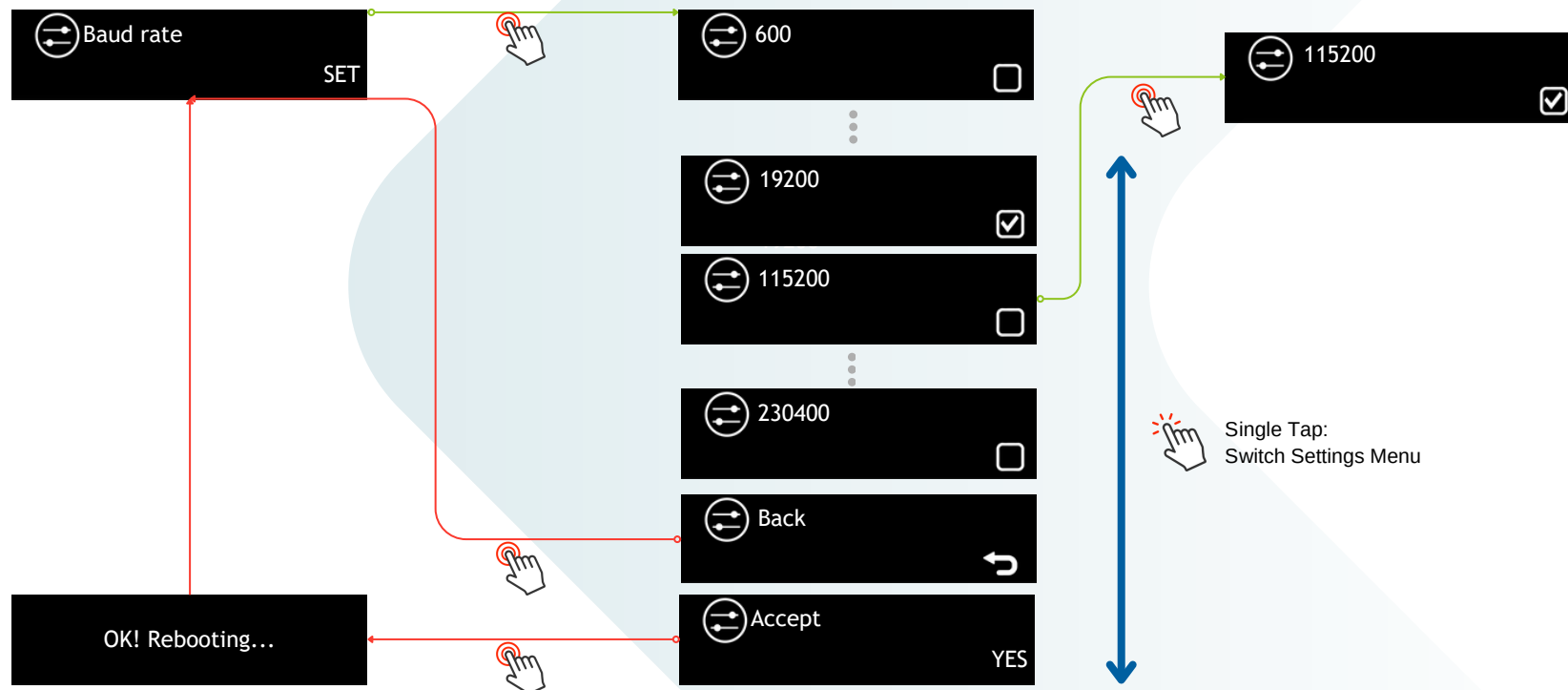

NOTES:

[1] If there is no operation within 10 seconds:

- Changed settings will be applied automatically.
- If no changes are made, the menu returns to the previous level.

Gesture Instructions

- [1]Single Tap: Press the button once
- [2]Double Tap: Press the button twice

ADVANCED SETTINGS - MODBUS DEVICE ADDRESS

- **[Modbus ID]** : Device address in the Modbus communication protocol

See [\[Advanced Settings - Main Screen\]](#) for details. After entering the Advanced Settings menu, select the [Modbus ID] page. Double-tap the multifunction button to confirm and enter the submenu: [1]
This page allows changing the device address in the Modbus protocol. The factory default ID is 1, and supported addresses range from 1 to 247.

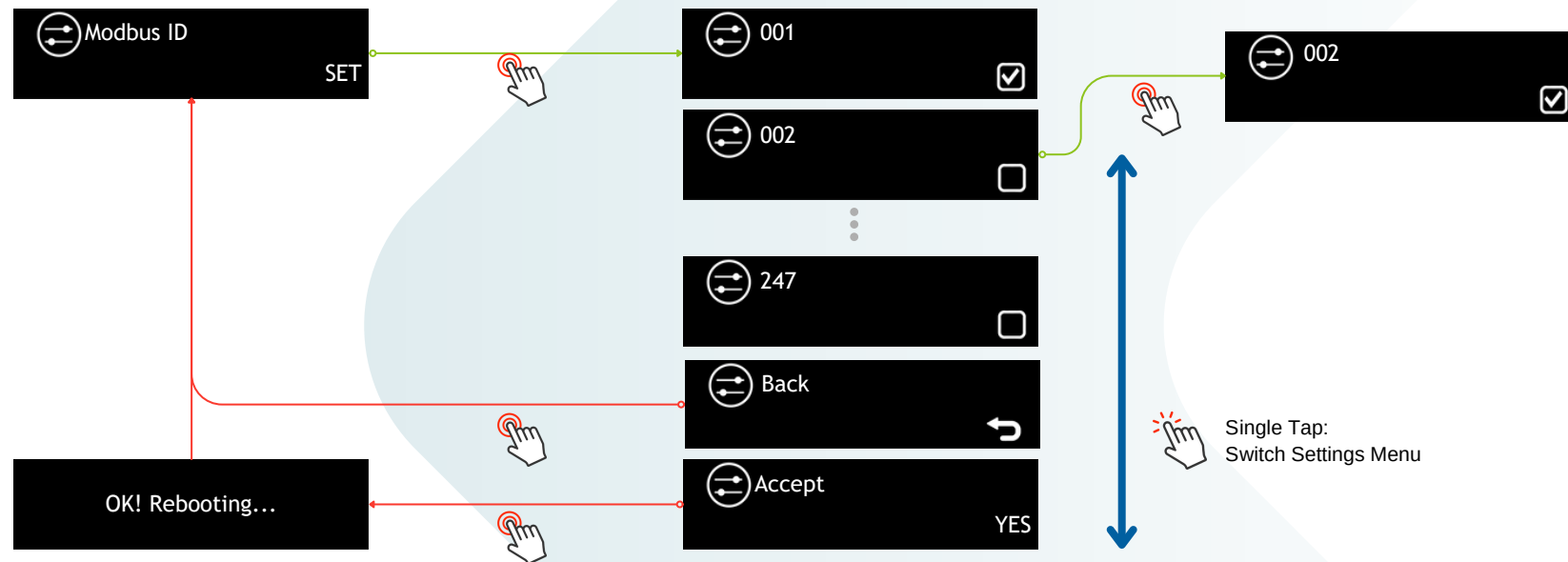

NOTES:

[1] If there is no operation within 10 seconds:

- Changed settings will be applied automatically.
- If no changes are made, the menu returns to the previous level.

Gesture Instructions

- [1]Single Tap: Press the button once
- [2]Double Tap: Press the button twice

ADVANCED SETTINGS - CHANGE MAIN DISPLAY MODE

- **[Display mode]** : Change main display mode

See [\[Advanced Settings - Main Screen\]](#) for details. After entering the Advanced Settings menu, select the [Display Mode] page. Double-tap the multifunction button to confirm and enter the submenu:^[1]

This page allows changing the display mode of the device's main screen ^[2]

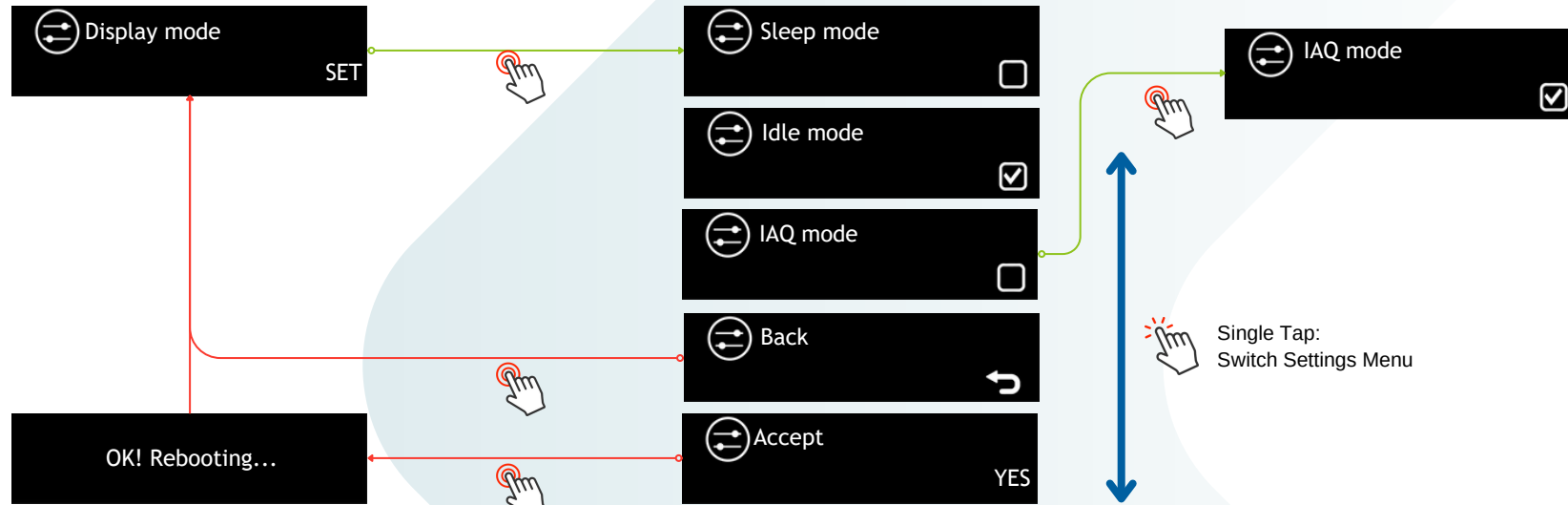

NOTES:



[1] If there is no operation within 10 seconds:

- Changed settings will be applied automatically.
- If no changes are made, the menu returns to the previous level.

[2] The main screen has 3 modes:

- Sleep Mode: Screen off, no information displayed.
- Idle Mode: Screen in standby; only connection status, air quality alert icons, and RS-485 communication status are shown.
- IAQ Mode: Screen cycles through air quality information.

Gesture Instructions

-  [1]Single Tap: Press the button once
-  [2]Double Tap: Press the button twice

ADVANCED SETTINGS - CHANGE DISPLAY UNIT

- **[Unit]** : Change display unit [2]

See [\[Advanced Settings - Main Screen\]](#) for details, After entering the Advanced Settings menu, select the [Unit] page. Double-tap the multifunction button to confirm and enter the submenu: [1][3]

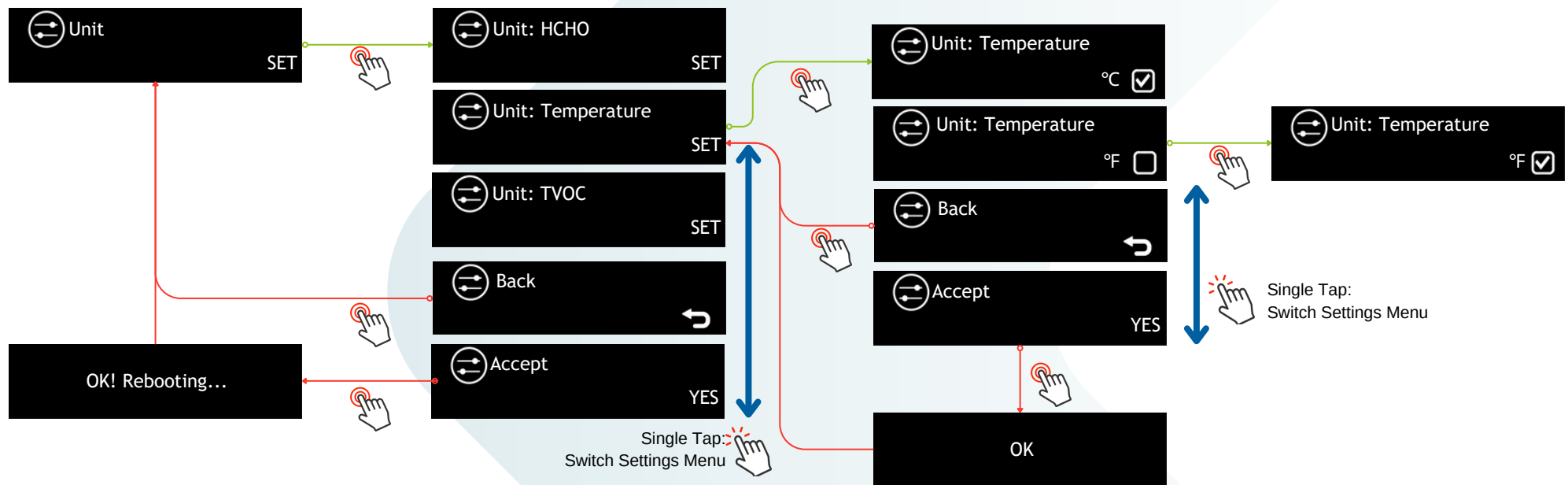

NOTES:

[1] If there is no operation within 10 seconds:

- Changed settings will be applied automatically.
- If no changes are made, the menu returns to the previous level.

[2] Only displays installed/enabled factors.

[3] Selectable units are as follows:

- HCHO = Formaldehyde
 - ppm (Parts per million), $\mu\text{g}/\text{m}^3$ (Micrograms per cubic meter)
- T = Temperature
 - °C (Celsius), °F (Fahrenheit)
- TVOC = Total Volatile Organic Compounds
 - ppm (Parts per million), $\mu\text{g}/\text{m}^3$ (Micrograms per cubic meter)

Gesture Instructions

- [1] Single Tap: Press the button once
- [2] Double Tap: Press the button twice

ADVANCED SETTINGS - DEVICE RESTART

- **[Reboot]** : Device Restart [2]

See [\[Advanced Settings - Main Screen\]](#) for details. After entering the Advanced Settings menu, select the [Reboot] page. Double-tap the multifunction button to confirm and restart the device:[1]



- **[Back]** : Return to Main Screen

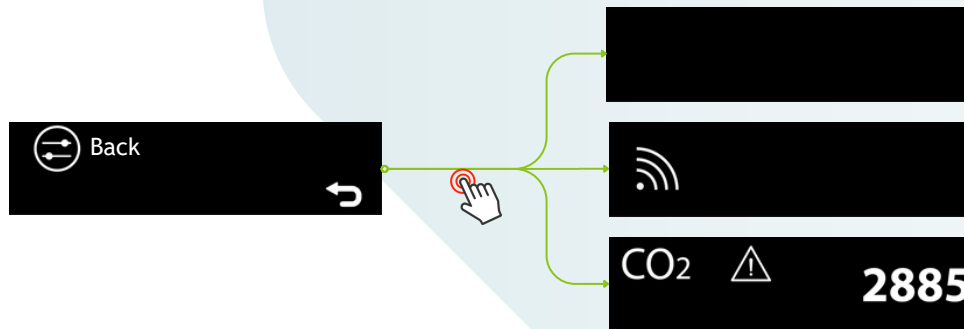

See [\[Advanced Settings - Main Screen\]](#) for details. After entering the Advanced Settings menu, select the [Back] page. Double-tap the multifunction button to confirm and return to the main screen:[1]



NOTES:

- [1] If there is no operation within 10 seconds, the menu automatically returns to the previous level.
- [2] The screen will display "Rebooting..." and the device will restart.

Gesture Instructions

-  [1]Single Tap: Press the button once
-  [2]Double Tap: Press the button twice

CONNECT TO WI-FI HOTSPOT

iAeris7 hotspot is enabled by default for direct phone or computer connection

1.

Power on iAeris7 and check for the hotspot icon . (If not in hotspot mode, go to [\[Advanced Settings - Reset wi-fi settings\]](#), then find the hotspot name on the rear label.

Find the WiFi hotspot name on the label on the back of the device.

SSID: **iAeris7_xxxx** [1]

Password: **1234567890**

| | | |
|-----------------------------|----------------------------|--|
| Model : iAeris7x | [WiFi Setting] | |
| Serial no : 00000000000xxxx | SSID : iAeris7_xxxx | |
| WiFi Mac : xxxxxxxxxxxx | Password : 1234567890 | |
| BLE Mac : | http://192.168.4.1/config? | |

[2]

2.

Open your phone or computer, search for, and connect to the iAeris7 Wi-Fi hotspot [3]

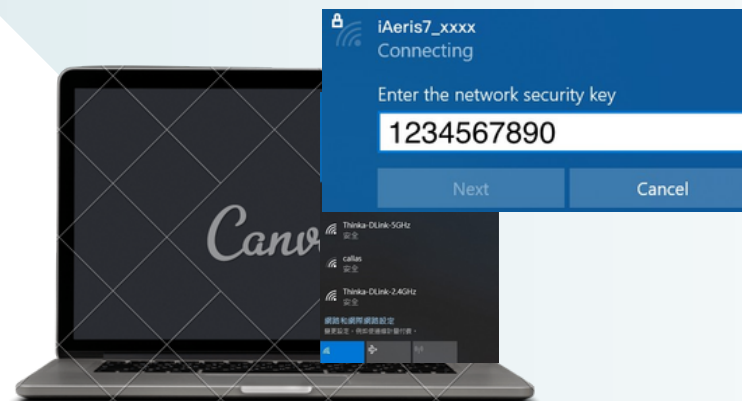
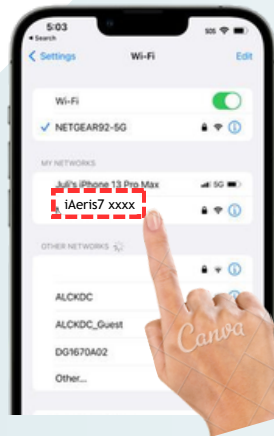

NOTES:

[1] XXXX = last 4 digits of Wi-Fi MAC

[2] This figure is for reference only. Displayed information may vary between devices.

[3] If the device hotspot cannot be found, check whether it is hidden or turned off. See [\[Device Status screen\]](#) for Wi-Fi SSID (Network Name) details.

RESET DEVICE WI-FI SETTINGS:

If the iAeris7 screen does not show the hotspot icon or the Wi-Fi hotspot cannot be found, press and hold the multifunction button for 3 seconds to enter the Settings menu. Select "Reset Wi-Fi & Reboot." After the device restarts, it will enter setup mode and automatically enable the Wi-Fi hotspot.

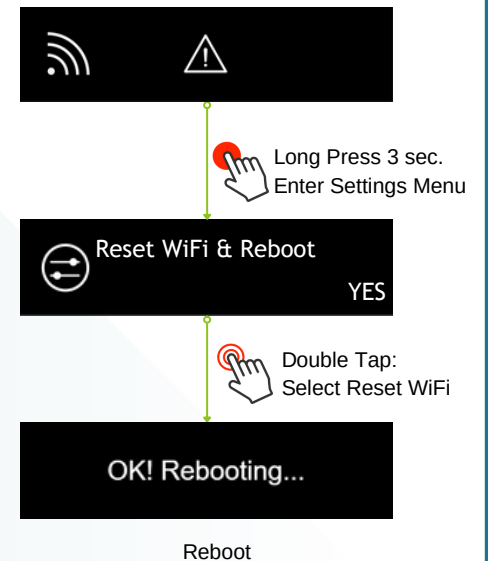

LOG IN TO THE CONFIGURATION WEBPAGE

iAeris7 supports remote setup via computer or phone when connected to a network.

1.

Power on iAeris7 and go to the Device Status screen [1] to view connection info and network IP address [2]

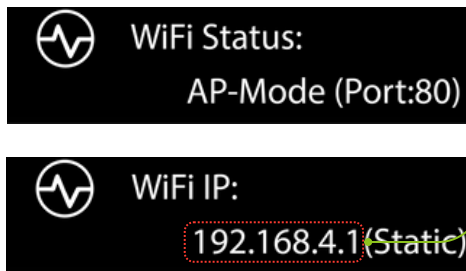

2.

Using a computer or phone browser, enter the network address 「http://xx.xx.xx.xx」 [3] in the address bar to access the settings page

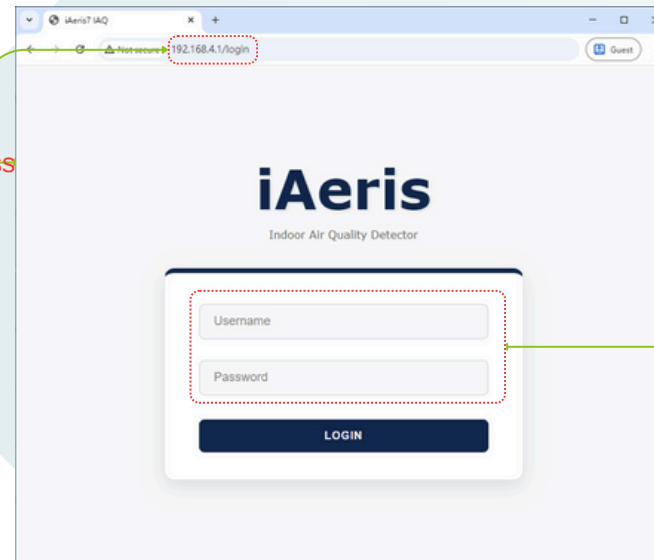

Network Address

3.

Enter the username and password to log in:

iAeris7 offers two login modes: 「General Mode」 and 「Engineer Mode」:

- **[General]** Default username and password: [5]

username: admin
password: admin

- **[Engineer]** For authorized personnel only; contact Sysinno service for credentials

NOTES:

- [1] For first-time use, the device will be in setup mode (Wi-Fi hotspot enabled). Please connect to the iAeris7 Wi-Fi hotspot first.
- [2] Connection info shows both Wi-Fi and Ethernet IP addresses. Users can choose either based on their actual connection.
- [3] 「http://xx.xx.xx.xx」 is an example; enter the actual IP. In hotspot mode, the IP address is fixed at 192.168.4.1
- [4] XXXX = last 4 digits of the Wi-Fi MAC.
- [5] The username and password can be changed by the user. See the attached [\[iAeris7 Web Settings – Password Setup\]](#) for details.

WIRELESS (WI-FI) SETUP PROCEDURE

After logging in, click "Network Setting " to access Wi-Fi setup.

1. Choose the WiFi AP you want to connect to
 - ! Note: The displayed AP is the user's WiFi AP. "sysinno-test" is just an example
 - ! If iAeris7 can't find your WiFi AP, you can manually enter the "SSID."

2. Enter the password
 - ! Note: Enter your WiFi AP password, not the iAeris7 hotspot password "1234567890"

3. Check the settings option
 - ! For details on DHCP, Cloud Config, or Upload Cloud options, see [[Network Settings](#)]

4. Once settings are complete, click "Accept."

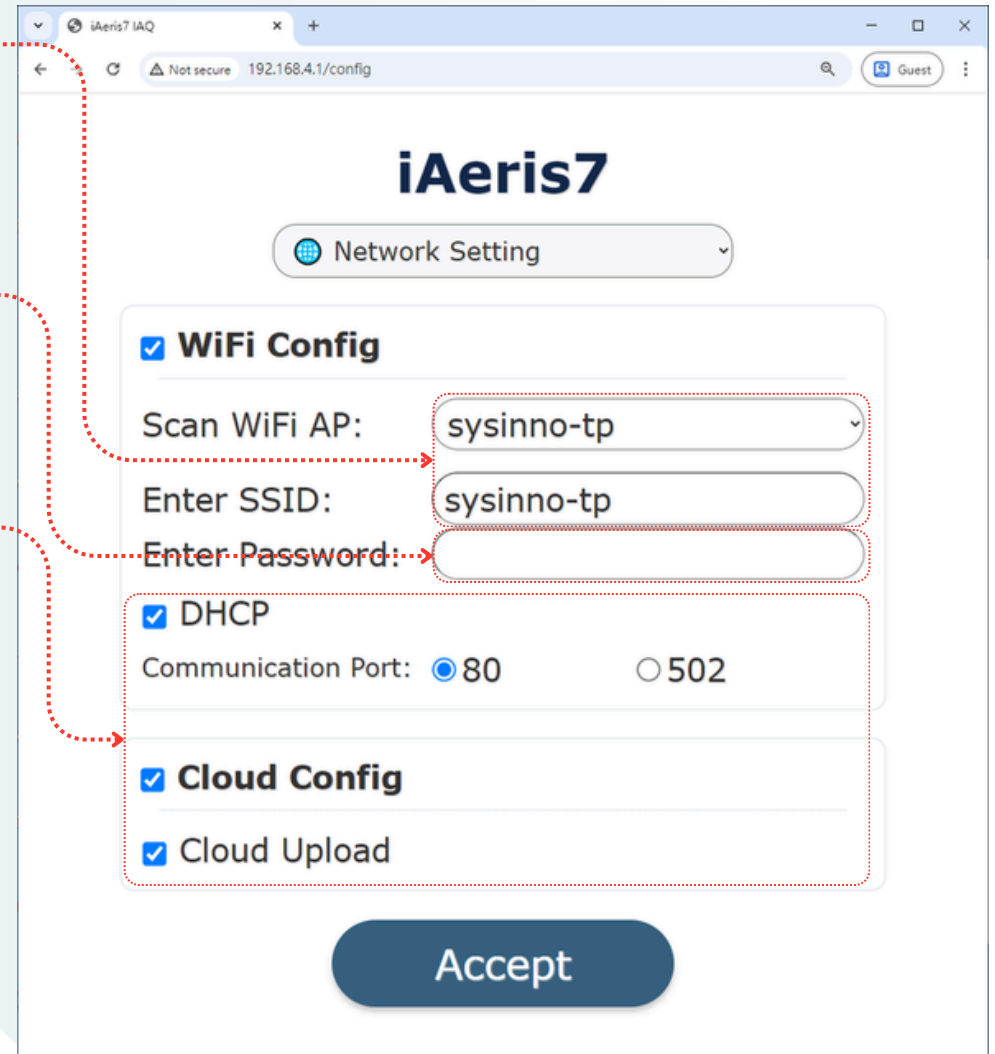

The screenshot shows the iAeris7 Network Setting page. The 'WiFi Config' section is active, showing a dropdown menu for 'Scan WiFi AP' with 'sysinno-tp' selected. Below it are input fields for 'Enter SSID' (containing 'sysinno-tp') and 'Enter Password'. The 'DHCP' section is also active, with 'Communication Port' set to 80. At the bottom, the 'Cloud Config' section is active, with 'Cloud Upload' checked. A large 'Accept' button is at the bottom right.

NOTES:

For details on logging in to the settings page, see the attached [[iAeris7 Web Settings Guide](#)]

WIRELESS (WI-FI) SETUP PROCEDURE

5____. Countdown for setup completion

6____. Setup done, “OK” displayed[1]

iAeris WiFi Setting

Please wait 19 sec

iAeris WiFi Setting

| | |
|------------|---------------|
| WiFi Link | OK |
| Join AP | sysinno-tp |
| IP Address | 192.168.0.104 |
| Cloud | OPEN |
| ModBus-TCP | CLOSE |

System Reboot!!

NOTES:

[1] If "NG" appears, check AP or password. Click "BACK" to retry step 1.

iAeris WiFi Setting

| | |
|------------|-----|
| WiFi Link | NG |
| Join AP | --- |
| IP Address | --- |
| Cloud | --- |
| ModBus-TCP | --- |

CLOUD PLATFORM INTERFACE (OPTIONAL)

Go to <https://xsize.net/iaeris/login.php> in your browser

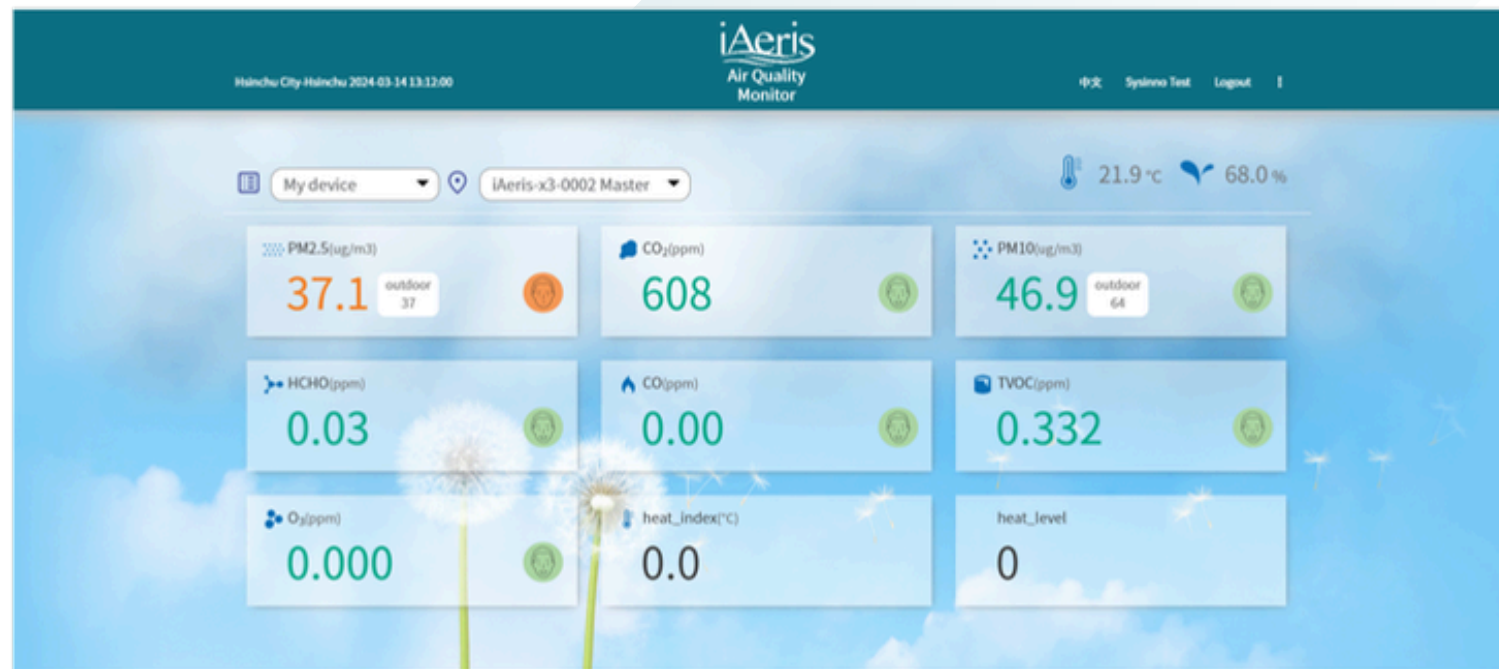

CLOUD PLATFORM INTERFACE (OPTIONAL)

Register Account



The screenshot shows the registration page for iAeris Air Quality Monitor. The page has a teal header with the iAeris logo and navigation links for '中文', 'Login', and 'Register'. A hand cursor icon is pointing at the 'Register' link. The main content area is titled 'Register account' and contains five input fields: 'Account, registered email address', 'Password, 10 or more English, Number...', 'Confirm the password and enter the password', 'Member name, please enter a name', and 'please select monitor type'.

iAeris
Air Quality
Monitor

中文 Login Register

Register account

Account, registered email address

Password, 10 or more English, Number...

Confirm the password and enter the password

Member name, please enter a name

please select monitor type

CLOUD PLATFORM LOGIN HOMEPAGE

- After registration and login, view the environmental detection values of the selected device
- Data uploads to the cloud platform every six minutes

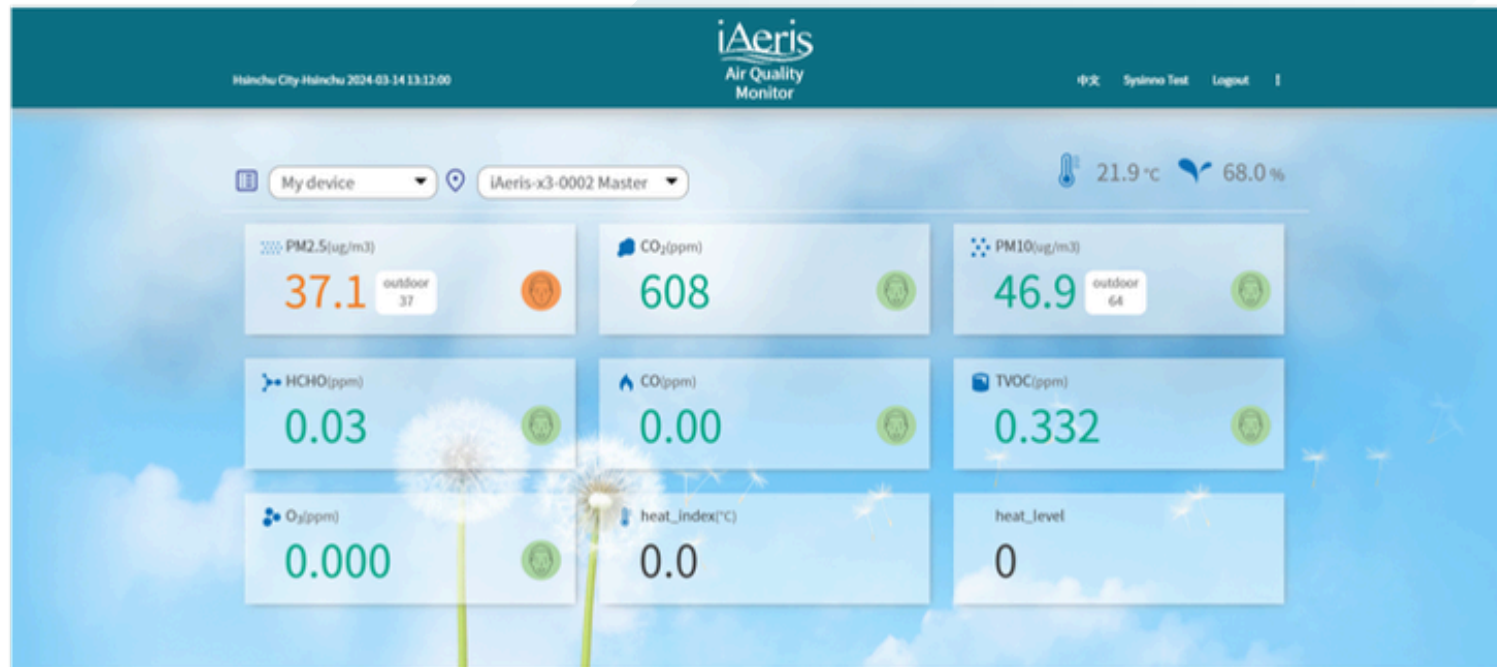

HISTORICAL DATA TREND CURVE

- Click "Environmental Factors" on the homepage to access the historical curve interface.



- This page shows hourly averages and up to seven days of data.



CUSTOMER AREA FUNCTIONALITY

- The cloud platform provides customer-oriented features for easy data recording and management.
- Before service expires, contact the device vendor to purchase additional usage years for continued data download functionality.



The screenshot displays the iAeris Air Quality Monitor web interface. At the top, the header includes the location and time 'Hainchu City Hainchu 2024-03-14 13:24:00', the iAeris logo, and navigation links for '中文', 'Sysinno Test', and 'Logout'. The main content area features a 'Download History Data' form with the following fields:

- A dropdown menu set to 'My device'.
- A dropdown menu labeled 'Please select the monitoring device'.
- A date input field containing '2024-02-28 13:29'.
- The word 'to' centered between two date input fields.
- A date input field containing '2024-03-14 13:29'.
- A dropdown menu set to 'Every'.
- A 'Download' button.

The background of the form area shows a scenic view of mountains and dandelions. The footer contains copyright information: 'Copyright © 2021 Sysinno Technology Inc. All rights reserved.', along with contact details: 'service@sysinnotec.com' and '+886-3-5730550'.

INSTALLATION POSITION RECOMMENDATIONS

For accuracy, we recommend installing one detector for every 200 square meters of enclosed space.

For example:

- Each open space of 200 square meters requires one detector.
 - Each individual partitioned meeting room or space requires one detector.
 - For spaces larger than 200 square meters, consider installing multiple detectors throughout the entire area to achieve optimal coverage.
 - Detectors should be installed near indoor areas where people are active or near ventilation (air conditioning) equipment return air vents.
 - Detector placement should be away from operable doors, windows, and air conditioning vents, at least 2 meters away.
-
- We recommend installing the detector at a height of 1.5 meters to 2.5 meters.
 - Position the detector at least 2 meters away from doors, windows, and air vents.
 - Ensure that the device's ventilation holes are not obstructed, allowing for proper airflow.
 - To ensure accuracy and longevity, ceiling-mounted installation on the ceiling is not recommended.

PRECAUTIONS

- This product provides general indoor air quality information only and is not intended to determine individual health impacts or serve as a fire alarm.
- Keep the product away from heat sources and areas prone to water splashes or dripping.
- Avoid using the product in environments with vibrations or direct sunlight.
- Ensure proper airflow by not blocking the ventilation holes around the device.
- Do not insert external objects into the ventilation holes to prevent sensor malfunction or electric shock.
- Non-technical personnel should not attempt to disassemble, modify, or repair the product.
- Use correct connectors and cables during installation and avoid forcing connectors into ports to prevent damage not covered by warranty.

【Attention】 Power Supply Notice:

- This product operates on a 12-24V DC power supply. You can either convert AC power to the required voltage or use the provided power adapter.

【Attention】

- This product supports energy recovery ventilation (ERV) and single-directional intake fans. Before purchasing, consult local distributors for compatibility and technical support.
- The control logic for RS485 or dry contact output is fixed and intended only for ventilation equipment control.

Use the correct connectors and ports

- Avoid forcing connections. Check for obstructions. Ensure proper alignment.
- Damage from mishandling, like inserting wrong pins, isn't covered by warranty.

Power Supply Specifications:

This product can be powered by the included an adapter or a 24VDC power source. The included transformer outputs 5V via a Micro USB connector. If using a 24VDC power source, convert mains power to 12-24V before wiring it to the rear port.

Dry Contact Specifications:

The dry contact is a passive NO switch. AC rated voltage withstands 125V at 0.3A, and DC withstands 30V at 1A.

Prohibition of Hot Wiring

When changing the power source or port terminals, be sure to cut off power before wiring adjustments, and reconnect power only after completing the setup.

Contents

- **LOGIN:**
 - Login modes and username/password
- **INFORMATION:**
 - Information page description
- **DISPLAY SETTINGS:**
 - Display page description
- **NETWORKING SETTINGS:**
 - Network settings description
 - [\[WiFi Config\] section description](#)
 - [\[Cloud Config\] section description](#)
- **PASSWORD SETTINGS:**
 - Password page description
- **DATA DOWNLOAD:**
 - Data page description
- **TIME SETTINGS:**
 - Time page description
- **ADVANCED SETTINGS:**
 - Advanced settings page description
 - [\[Modbus RTU \(RS-485\)\]](#)
 - [\[Wi-Fi Access Point Settings\]](#)
 - [\[Cloud Upload Settings \(Engineer Mode\)\]](#)
 - [\[Restore Factory Settings \(Engineer Mode\)\]](#)

LOGIN PAGE DESCRIPTION

Using a computer or mobile browser, enter the URL [http://xx.xx.xx.xx] in the address bar to access the iAeris7 login page (as shown below)

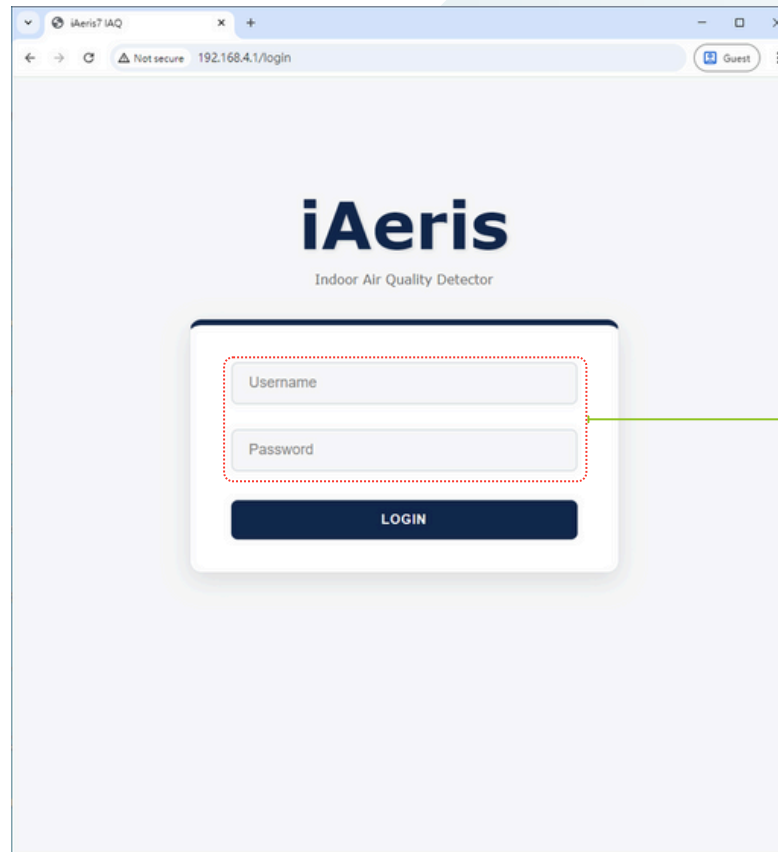

Login Mode and Username/Password

Aeris7 offers two login modes: 「General Mode」 and 「Engineer Mode」:

- [**General**] Default username and password:
username: admin
password: admin
- [**Engineer**] For authorized personnel only; contact Sysinno service for credentials

備註事項:

[1] [http://xx.xx.xx.xx] is an example; enter the actual IP

[2] If iAeris7 is in AP-Mode, the default login IP address is [<http://192.168.4.1>] when accessed via computer or mobile device.

INFORMATION PAGE DESCRIPTION

The Information page displays local iAeris device details (see example below).

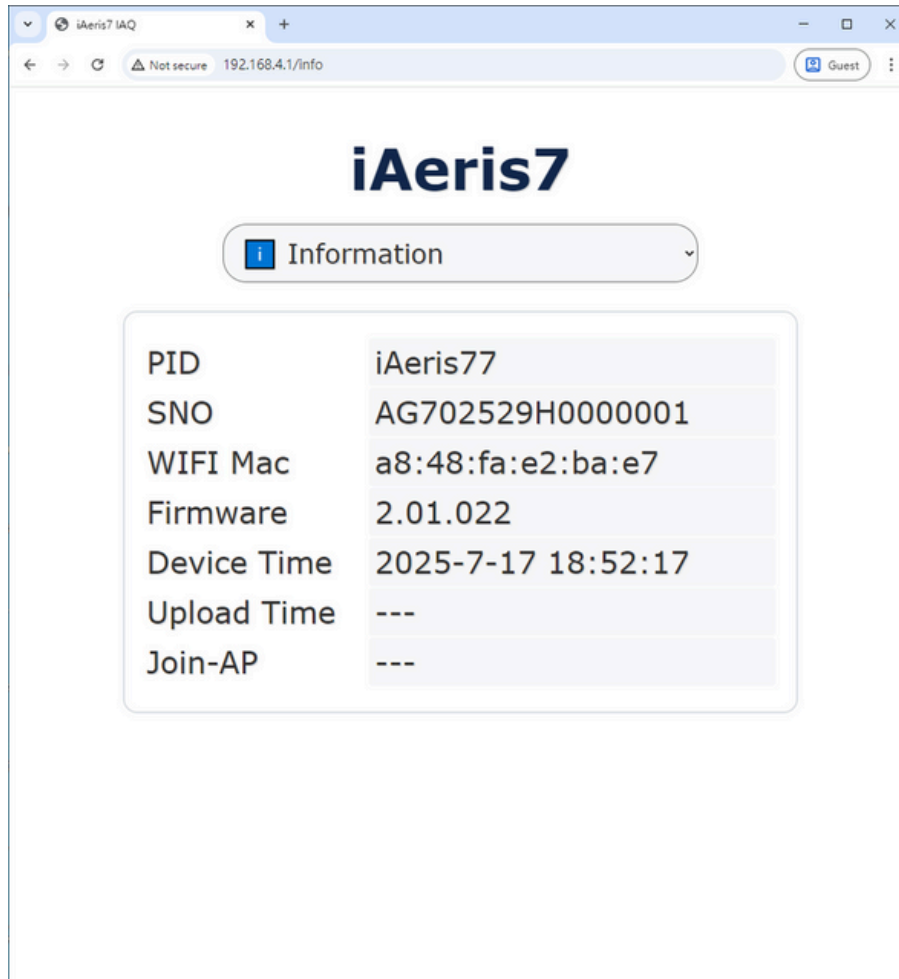

- **[PID]:**
 - Model iAeris7, last digit shows number of installed sensors.
- **[SNO]:**
 - Unique 15-character product serial number.
- **[WIFI Mac]:**
 - Device Wi-Fi MAC address.
- **[Firmware]:**
 - Installed firmware version.
- **[Device Time]:**
 - Device RTC time.
- **[Upload Time]:**
 - Last successful cloud upload time.
- **[Join-AP]:**
 - Currently connected Wi-Fi SSID.

DISPLAY SETTING PAGE DESCRIPTION

This page lets users configure screen display settings. [1]

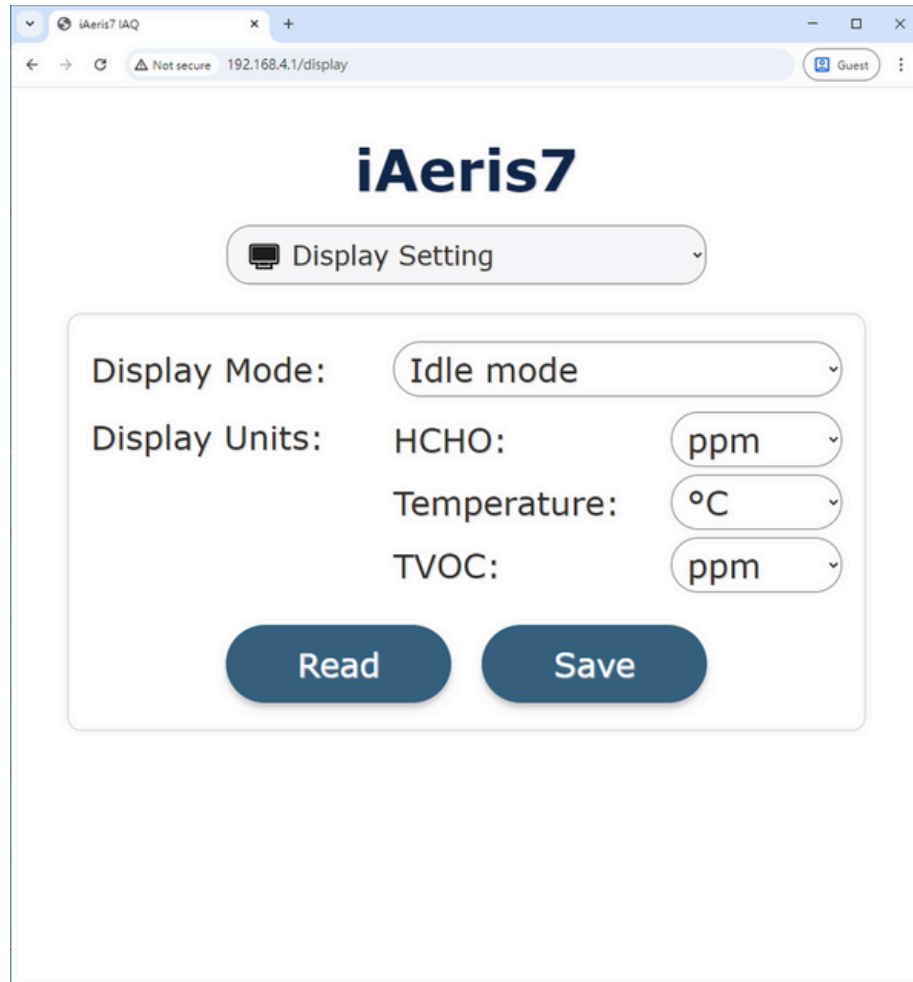

NOTES:

[1] If no screen is installed, this function is unavailable.

[2] If the above sensor is not installed, its option will not be displayed.

- **[Display Mode]:**

- Set OLED screen display mode:
 - **Sleep mode:** Screen off.
 - **Idle mode:** Shows Wi-Fi, alarm, and RS-485 status.
 - **IAQ mode:** Cycles through all sensor readings.

- **[Display Units]:**

- Set the concentration units for the sensor readings displayed on the screen [2]. Supported units:
 - **HCHO (Formaldehyde):**
 - ppm (parts per million)
 - $\mu\text{g}/\text{m}^3$ (micrograms per cubic meter)
 - **Temperature:**
 - °C (Celsius)
 - °F (Fahrenheit)
 - **TVOC (Total Volatile Organic Compounds):**
 - ppm (parts per million)
 - $\mu\text{g}/\text{m}^3$ (micrograms per cubic meter)

[WiFi Config] Section Description

The Network Settings page has two sections: [WiFi Config] and [Cloud Config]. The following explains the [WiFi Config] section:

1. WiFi Section

Check [WiFi Config] to apply the settings in the Wi-Fi section; uncheck to ignore them.

- **[Scan WiFi AP]:**
 - The device scans for available wireless access points (SSIDs).
- **[DHCP]:**
 - Check to enable automatic IP and network settings from the access point;
 - **uncheck to manually set device IP address, subnet mask, and gateway.**
- **[Communication port]:**
 - Select either port 80 (HTTP) or port 502 (Modbus TCP) as the device communication port.

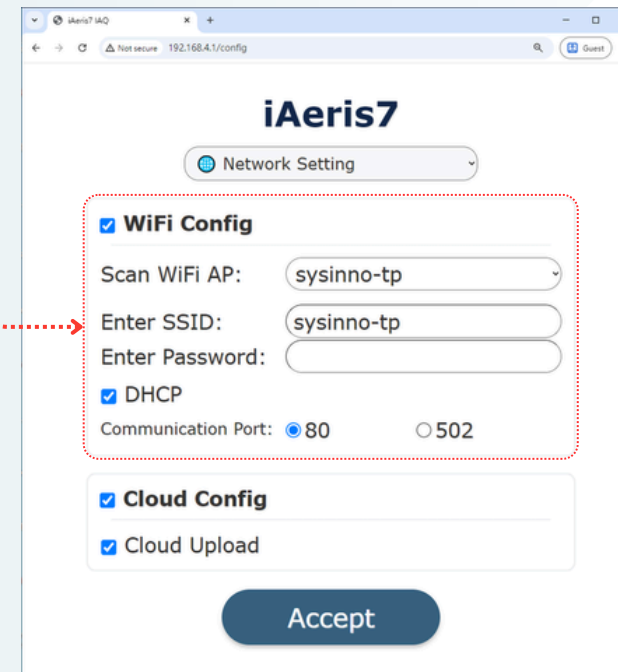

Uncheck [DHCP] and enter the network settings manually.]



[Cloud Config] Section Description

The following explains the [Cloud Config] section settings:

2. Cloud Section

Check [Cloud Config] to apply the settings in the Cloud section; uncheck to ignore them.

- **[Upload Cloud]**: Check to enable data upload to the cloud server. The device will automatically upload data to the default cloud server [1]. Different cloud types require different configuration parameters [2].

iAeris7 supports the following cloud upload methods:

- SYSINNO cloud (HTTP) - **Default (SYSINNO Cloud platform)**
- SYSINNO cloud (MQTT)
- Custom cloud (HTTP)
- Custom cloud (MQTT)
- iCap Air

NOTES:

[1] The image on the right shows the SYSINNO cloud platform settings, which is also the device's default cloud server.

[2] If users want to change the cloud settings, they must go to Advanced Settings [\[Cloud upload settings\]](#)

SYSINNO cloud (HTTP) Setup: **Default**

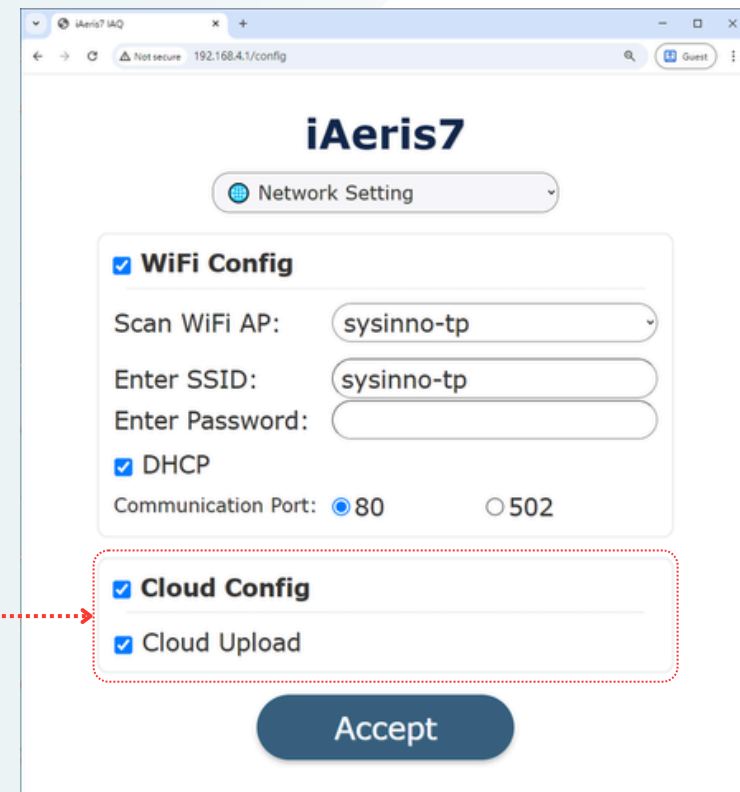

The screenshot shows the iAeris7 Network Setting configuration page. The 'Cloud Config' section is highlighted with a red dashed box, and an arrow points from the text 'The image on the right shows the SYSINNO cloud platform settings' to this section.

WiFi Config

- Scan WiFi AP: sysinno-tp
- Enter SSID: sysinno-tp
- Enter Password: [Empty field]
- DHCP
- Communication Port: 80 502

Cloud Config

- Cloud Config
- Cloud Upload

Accept

[Cloud Config] Section Settings (Other Cloud Server Setup Methods)

Besides the default SYSINNO cloud platform, you can also configure other cloud servers:

SYSINNO cloud (MQTT) Setup:

Used with the installed SYSINNO on-premise server **i-Cap**. Users only need to check Upload and set the server IP address. The device will upload data via MQTT (as shown).

Contact SYSINNO sales for iCap details.



Cloud Config

Cloud Upload
MQTT Broker:

Custom cloud (HTTP) Setup:

Supports HTTP protocol to push data to the customer-specified server IP address and path, as shown below:

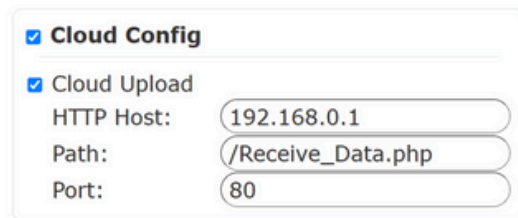

Cloud Config

Cloud Upload
HTTP Host:
Path:
Port:

iCap Air Setup:

Used with the installed Innodisk on-premise server **i-Cap Air**. Users only need to check Upload and set the server IP address. The device will upload data via MQTT (as shown). Contact SYSINNO sales for iCap Air details.

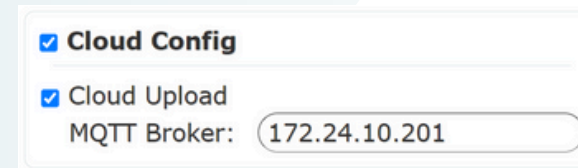

Cloud Config

Cloud Upload
MQTT Broker:

Custom cloud (MQTT) Setup:

Using MQTT v3 protocol, the device can send data to your specified MQTT broker IP address, topic, port, username, and password. All related configuration parameters are shown in the figure below.

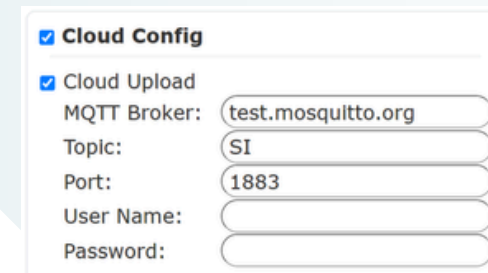

Cloud Config

Cloud Upload
MQTT Broker:
Topic:
Port:
User Name:
Password:

PASSWORD SETTINGS

Provides users the ability to change account information[1], including **username**, **new password**, and **password confirmation**.



- **[User Name]:**
 - Set a new login username
- **[New Password]:**
 - Set a new password
- **[Confirm Password]:**
 - Re-enter the new password for verification [2]

NOTES:

[1] Using the device interface [[Home Screen - Press and hold to reset the device](#)] or [[Reset WiFi & Password](#)] will restore the device username and password to the factory default values.

[2] If the two password entries do not match, the password change will not be completed.

DATA DOWNLOAD

iAeris7 supports downloading stored device data via the web interface (as shown).



- **[Device Time]:**
 - Current RTC time of the device
- **[Data Type]:**
 - Export [Raw data \(all\)](#) records.
- **[Memory]:**
 - Shows stored data [count](#) / [maximum](#) storage capacity
- **[Download]:**
 - Click to download stored data to your computer or mobile device.
 - File format is [.csv](#) , open with Excel or other spreadsheet software

NOTES:

- When the device reaches maximum data storage, it will automatically overwrite the oldest data.
- For large data volumes, downloading may take several seconds to minutes—please be patient.
- Ensure a stable network connection during export to avoid interruptions.

TIME SETTINGS

The iAeris7 RTC time can be set in two ways: **Network Time Sync** or **Manual Setting** (as shown).

Network Time Sync:

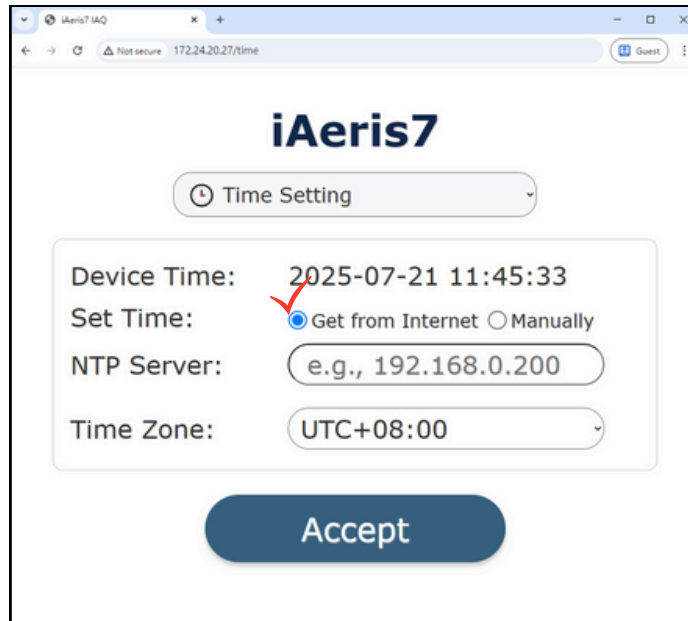

The screenshot shows the 'iAeris7' web interface for 'Time Setting'. The 'Time Setting' dropdown is selected. The 'Device Time' is 2025-07-21 11:45:33. Under 'Set Time', the 'Get from Internet' radio button is selected and has a red checkmark. The 'NTP Server' field contains 'e.g., 192.168.0.200'. The 'Time Zone' dropdown is set to 'UTC+08:00'. A blue 'Accept' button is at the bottom.

- Check [Get from Internet] to have the device obtain time from an NTP server and automatically sync the RTC [1]
- In the [NTP Server] field, enter the NTP server address.
- In the [Time Zone] field, select the device's local time zone to ensure correct network time synchronization [2] (e.g., UTC+08:00 Taipei) [2] (e.g.,: UTC+08:00 Taipei)

Manual Setting:

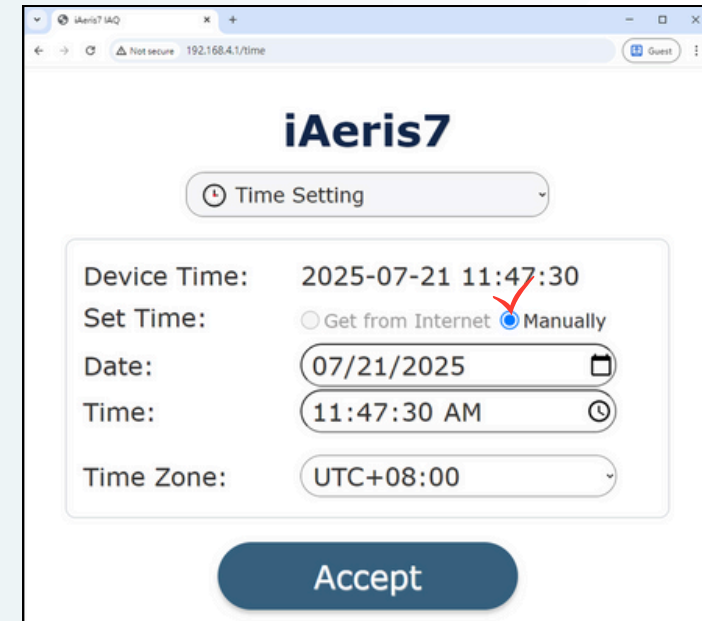

The screenshot shows the 'iAeris7' web interface for 'Time Setting'. The 'Time Setting' dropdown is selected. The 'Device Time' is 2025-07-21 11:47:30. Under 'Set Time', the 'Manually' radio button is selected and has a red checkmark. The 'Date' field contains '07/21/2025'. The 'Time' field contains '11:47:30 AM'. The 'Time Zone' dropdown is set to 'UTC+08:00'. A blue 'Accept' button is at the bottom.

- Check [**Manually**] to set the device date and time manually.
- [**Date**] Enter the current date
- [**Time**] Enter the current time
- [**Time Zone**] Select the device's local time zone to ensure correct time settings [2] (e.g., UTC+08:00 Taipei)

NOTES:

[1] If the device is in **AP-Mode** or **offline** , automatic network time sync cannot be used; select manual time setting instead.

[2] Correct time zone setting affects all time-related functions, such as data logging and upload timestamps.

ADVANCED SETTINGS

The Advanced Settings page integrates multiple key configuration functions, helping users manage **advanced communication, network, cloud, and system reset options** [1]

It is mainly divided into the following sections:



- **[Modbus RTU (RS-485) Communication Settings]:**
 - This section is used to configure Modbus RTU (RS-485) communication parameters between iAeris7 and upstream devices.
- **[Wi-Fi Hotspot Settings]:**
 - This section is used to configure the iAeris7 Wi-Fi hotspot mode for different application scenarios.
- **[Cloud Upload Settings (Engineer Mode)]:** [2]
 - This section is used to configure parameters for uploading device data to a cloud server.
- **[Restore Factory Settings (Engineer Mode)]:** [2]
 - This section is used to restore the device to its factory settings.

NOTES:

[1] Advanced settings can change important device parameters; please configure with caution.

[2] **[Engineer Mode]** is for authorized personnel only. Contact SYSINNO sales to obtain credentials before use.

ADVANCED SETTINGS

Modbus RTU (RS-485) Communication Settings:

Modbus ID:

Baud Rate:

- **[Modbus ID]:**
 - This ID distinguishes multiple Modbus devices; range is 1–247.
- **[Baud Rate]:**
 - Set the Modbus RTU communication baud rate. Supported options:
 - 600, 1200, 2400, 4800, 9600, 19200, 115200, 230400

Wi-Fi Hotspot Settings: (This section configures the iAeris7 Wi-Fi hotspot mode for different application scenarios) [1]

WiFi AP Setting:

- **[WiFi AP Setting]:**
 - Broadcast SSID (Visible):
 - In this mode, the Wi-Fi hotspot is **publicly visible**. Other devices can find and connect to the hotspot (SSID) directly.
 - Hide SSID (Invisible):
 - In this mode, the Wi-Fi hotspot is **hidden**. Other devices cannot detect it. Users must manually enter the SSID and connection key to connect.
 - Auto turn off when idle (30 minutes):
 - In this mode, the Wi-Fi hotspot **automatically turns off after 30 minutes of inactivity**. [1]

NOTES:

[1] To re-enable the device Wi-Fi hotspot, use one of the following methods:

1. Restart the device
2. Use the multifunction button to set Wi-Fi AP to Broadcast SSID (Visible) or Hide SSID (Invisible)

For detailed instructions, see [\[Advanced Settings - Configure Wi-Fi Hotspot\]](#)

ADVANCED SETTINGS

Cloud Upload Settings (Engineer Mode): [1] (This section configures parameters for uploading device data to a cloud server)

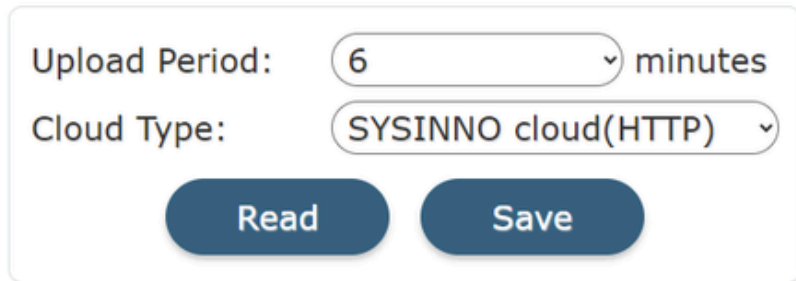

The screenshot shows a configuration panel for Cloud Upload Settings. It includes two input fields: 'Upload Period' with a dropdown menu set to '6' and the unit 'minutes', and 'Cloud Type' with a dropdown menu set to 'SYSINNO cloud(HTTP)'. Below these fields are two buttons: 'Read' and 'Save'.

- **[Upload Period] :**
 - Set the frequency for storing data locally and uploading to the cloud server. [Adjustable from 1 to 60 minutes](#) according to requirements.
- **[Cloud Type] :** [2]
 - SYSINNO cloud (HTTP)
 - SYSINNO cloud (MQTT)
 - Custom cloud (HTTP)
 - Custom cloud (MQTT)
 - iCAP Air
 - Factory default cloud

Restore Factory Settings (Engineer Mode): [3]

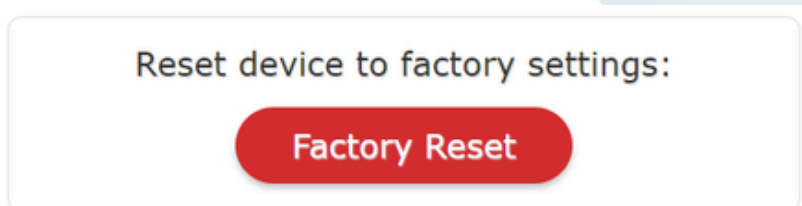

The screenshot shows a 'Reset device to factory settings:' section with a single red button labeled 'Factory Reset'.

- **[Factory Reset] :**
 - One-Click Restore restores all settings to factory defaults. [3]

NOTES:

[1] **[Engineer Mode]** is for authorized personnel only. Contact SYSINNO sales to obtain credentials before use.

[2] Different cloud platforms require corresponding server parameters such as address, username, and password. Changing this setting will affect the related parameters in the [\[Cloud Config\]](#) section on the Network Settings page. See [\[Cloud Config\]](#) for details.

[3] Executing this function will erase all custom settings. Use with caution.